

## RESIDENTIAL GAS WATER HEATERS

Lochinvar's Power Vented residential gas models are available in 40, 50 and 75 gallon capacities, feature a power vent system for sidewall or rooftop termination.

### STANDARD FEATURES

- **Code Compliance** – Complies with the Federal Energy Conservation Standards effective April 16, 2015, in accordance with the Energy Policy and Conservation Act, (EPCA), as amended.
- **Power Vented Exhaust System** – A quiet and efficient blower provides power vent operation through 2", 3" or 4" PVC, CPVC or Polypropylene vent pipe and plug into a standard 110v/120v outlet with a 6 foot power cord. The vent may terminate through a sidewall or the roof and may run up to 180 equivalent feet.
- **Flammable Vapor Ignition Resistant** – An air intake snorkel elevates the combustion air openings which prevents flammable vapors from entering the combustion chamber.
- **Electronic Gas Control** – The gas valve features hot surface ignition, control logic for precise temperature control and an LED status indicator for simplified service diagnostics. The design includes a safety thermal high limit switch, a flammable vapor sensor and protection from lint, dust and oil buildup.
- **Glass-Lined Steel Tank** – The durable glass lining is fused to the steel tank at 1600°F to assure lasting protection against rust and corrosion while providing clear, clean hot water. 300 PSI test pressure; 150 PSI working pressure.
- **Non-CFC Foam Insulation** – A uniform coverage of thick closed-cell foam insulation minimizes standby heat loss, maximizes heat retention and delivers a high Energy Factor.
- **Tank Saver Anode** – A large diameter, high capacity anode inhibits corrosion of the tank interior for long, trouble-free service.
- **Heat Trap** – Heat traps are built into the inlet and outlet connections to eliminate heat migration and heat loss in the water piping.
- **Sight Glass** – A built-in sight glass provides an unobstructed view of the burner and pilot flame.
- **Temperature & Pressure Relief Valve** – Factory installed for optimum safety.
- **Brass Drain Valve** – An enhanced ball valve design for effective drainage and positive shut-off.
- **6 Year Limited Tank & Parts Warranty\*** – See warranty sheet for details.
- **10 Year Extended Warranty** – Available for residential applications only.

\* 1-year limited tank & parts warranty when installed in a commercial application.

### RESIDENTIAL GAS WATER HEATERS POWER VENTED



Meets ASHRAE Energy  
Efficiency Standards



DESIGNED ★ ENGINEERED ★ ASSEMBLED

# USA

# Lochinvar®

# DIMENSIONS AND SPECIFICATIONS:

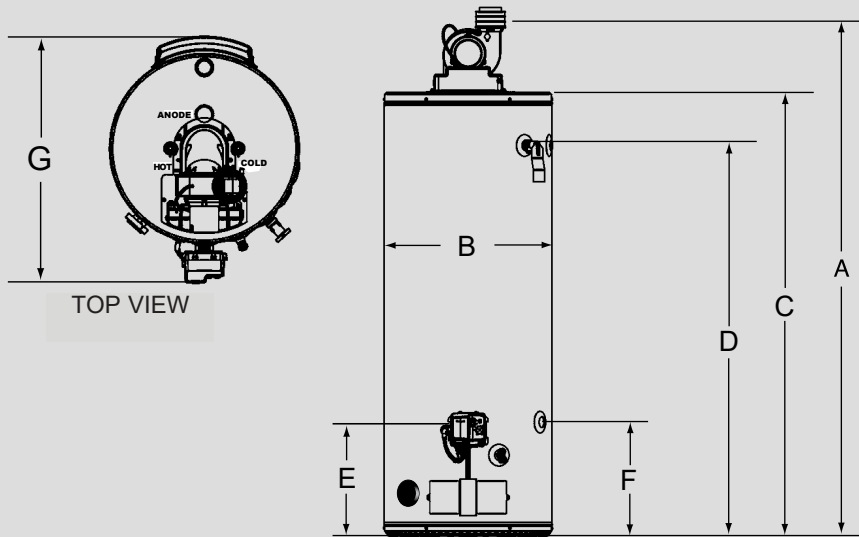

## MAX. VENT LENGTH (TOTAL EQUIVALENT FEET)

		2"	3"	4"
PVN040	40	50	125	180
PVN040	50	50	125	180
PVN050	40	50	125	180
PVN050	50	50	125	180
PVN050	65ST	N/A	50	125
PVN075	75ST	N/A	50	125

Model Number	Nominal Gal. Cap.	Rated Storage Cap.	Btu/Hr Input	UEF	1st Hr. Rating	GPH @ 90°F Rise	A	B	C	D	E	F	G	Gas Conn.	Water Conn.	Vent Size	Ship. Wt.
<b>Power Vented Models</b>																	
PVN040 40	40	38	40,000	0.67	73	45	59"	22"	49-3/4"	42-1/2"	13-1/4"	N/A	29-1/4"	1/2"	3/4"	2", 3" or 4"	174
PVN040 50	40	38	50,000	0.70	87	56	68-1/2"	20"	59-1/4"	53-1/4"	13-1/4"	15-1/4"	27-1/4"	1/2"	3/4"	2", 3" or 4"	176
PVN050 40	50	49	40,000	0.72	79	45	60-1/4"	24"	50-3/4"	43-3/4"	13-1/4"	N/A	31-1/4"	1/2"	3/4"	2", 3" or 4"	198
PVN050 50	50	48	50,000	0.72	97	56	68-1/4"	22"	58-3/4"	51-3/4"	13-1/4"	15-1/4"	29-1/4"	1/2"	3/4"	2", 3" or 4"	192
PVN050 65ST	50	50	62,000	0.73	119	69	61-1/4"	24"	52"	44-1/2"	13-1/4"	15-1/4"	31-1/4"	1/2"	3/4"	3" or 4"	212
PVN075 75ST	75	72	76,000	0.69	116	80	70-3/4"	26"	61-1/4"	53"	13-1/4"	15-1/4"	33-1/4"	1/2"	3/4"	3" or 4"	277

**Notes:** In the model number, "N" indicates Natural gas; replace "N" with "L" to indicate L.P. gas models. For the 50,000 Btu models, add "ST" to the model number for optional Side Tappings. (Ex: PVN04050ST) Side Tappings are standard on 62,000 and 76,000 Btu models and not available on 40,000 Btu/hr models.

### Certified for Potable Water and Space Heating Applications

This water heater is suitable for water heating and space heating. Toxic chemicals, such as those used for boiler water treatment shall NEVER be introduced into this system. This water heater may NEVER be connected to any existing heating system or components previously used with non-potable water heating appliances.

### FOR EASE IN ORDERING BY MODEL NUMBER

PV	N	040	40
Power Vented	Natural Gas	Gallon Capacity	Btu/hr Input

This is a Power Vented, residential, natural gas 40 gallon water heater with 40,000 Btu/hr input.

For technical information call 800-722-2101. Lochinvar, LLC reserves the right to make product changes or improvements without prior notice. Dimensions are approximate and should not be used for construction purposes.



Lochinvar, LLC  
300 Maddox Simpson Parkway  
Lebanon, Tennessee 37090  
P: 615.889.8900 / F: 615.547.1000  
f in y o Lochinvar.com